

RCI-600P Pipe Locating System

©Tianjin Grewin Technology Co.Ltd. We reserve all right in this document and in the information contained within. Reproduction, use or disclosure to third partners without express authorization is strictly forbidden.

V5.0



NOTICE

Thank you for choosing our devices.

Read the instruction carefully before using, specially pay attention to the security warning and tips.

Device is protected by below patents and we reserved all the rights:

2005 1 0012542.1 2005 1 0012543.6 2005 2 0024150.2

2005 2 0024149.X

2005 2 0024148.5

Please don't maintain device by yourselves. Contact us if any breakdown or error.

Sales dept.: salesmanager@grewin-tech.com

Service dept.: maggie@grewin-tech.com

Tel.: 86-22-84943756

Tianjin Grewin Technology Co.Ltd

Web:www.grewin-tech.com.

Add:DongLi Distr Tianjin City, China

Phone: +86-22-84943756

WhatsApp:+86-13072088960

Email: salesmanager@grewin-tech.com



CATALOG

- Before using (customers setting).....4
- 1. General description.....5
 - 1.1 General.....5
 - 1.2 Function feather.....5
 - 1.3 Specification.....6
 - 1.4 Device composition.....8
- 2. Common signal output mode.....10
 - 2.1 Direct connection mode.....10
 - 2.2 Clamp coupling mode.....14
 - 2.3 Radiation mode.....17
- 3. Signal transmitting method for cable detection.....20
 - 3.1 Signal transmitting method for dead cables.....20
 - 3.2 Signal transmitting method for live cables.....25
- 4. Pipe route tracing.....29
 - 4.1 Pipe route tracing (path tracing).....29
 - 4.2 Zone detection.....35
 - 4.3 Precise positioning.....37
 - 4.4 Depth measurement.....39
- 5. Cable identification.....43
 - 5.1 Clamp smart identification.....43
 - 5.2 Current measurement by clamp.....49
 - 5.3 Sensor identification.....49
- 6. Pinpoint for grounded fault of pipeline (optional function).....52
 - 6.1 Signal transmitting.....52
 - 6.2 Accessories connection.....53
 - 6.3 Interface introduction.....54
 - 6.4 Confirmatory tests at near-end.....54
 - 6.5 Fault locating confirmatory tests.....56



- 7. Cable fault pinpoint for low impedance and break fault.....58
 - 7.1 Phase to phase short circuit fault pinpointing.....58
 - 7.2 Phase to armor fault pinpointing.....61
 - 7.3 Break fault pinpointing.....62
 - 7.4 Break fault pinpointing.....64
- 8. Device maintain and warranty.....66
 - 8.1 Charging.....66
 - 8.2 Warranty and maintain.....66



BEFORE USING

For different countries and zones, we try to offer different user settings for choice. Now the power system frequency and depth measurement unit is optional.

1. Factory setting: default power frequency 50Hz, depth unit is meter
2. Optional setting as below:

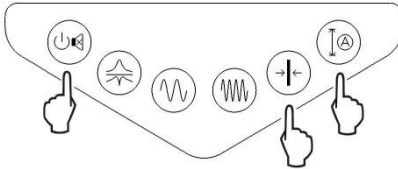

Check the receiver panel as below:



When the receiver power off, press Set ref button  and Measure button  together, at the same time press the ON/OFF button  to power on the device and the Welcome interface will appear.

Don't release buttons until below user setting interface appear.

User Setup
Power Freq: 50Hz Depth Unit: m

3. Press Set ref. button  to set the Power freq. to 50Hz or 60Hz.
4. Press Measure button  to set the Depth unit to M(meter) or FT(foot).
5. After setting long time press ON/OFF  button to power off device to finish the setting.
6. Customized setting will be kept when power off. If needed to change setting, modify it again following above steps.



1. GENERAL DESCRIPTION

1.1 GENERAL :

RCI-600P is a high performance underground metallic pipe locating system. It consists of a transmitter and a receiver, which can be used to do route tracing, pipe exploration and depth measurement of the underground cables and metallic pipes. It can also be used to identify target cable from a bunch of cables, locate pipe insulation damage and part

type cable fault.



Fig.1.1 device appearance

1.2 FUNCTION FEATURE:

- Compass display: to display pipe position directly.
- Left/right arrow indication: use the left/right arrow to indicate the pipe position when route tracing.
- Right/wrong indication: real-time test the pipe current direction to indicate tracing result and avoid the nearby lines interference.
- Real-time depth measure and current measure.
- History curve display: to display the signal variation directly.
- Cable Identification: Clamp (optional) identification and sensor identification. Clamp identification can precisely give accurate result. sensor (optional) identification could be used when the Clamp identification is not applicable.



- Grounding fault location: Use the A frame (optional) to pinpoint the pipe insulation damaged points against the ground. No need to do zero set and the arrow will point to the fault point direction.
- Digitization high accuracy sampling and processing, narrow receiving pass band to rise the anti-interference capability and suppress power interference and harmonic interference from nearby running cable and pipe.
- Multiple locating frequency: active detection and passive detection.
- Multiple signal output mode: Direct connection output, Clamp Coupling input, Radiation output.
- Big capacity Li-on batteries series, support auto power off when low battery or long time no operation
- Solid case and light weight easy to carry

1.3 SPECIFICATION:

1.3.1 Transmitter:

- Output: Direct Connection output, Clamp Coupling Output (optional), Radiation output.
- Output Frequency:
- 640Hz (complex frequency), 1280Hz (complex frequency), 10kHz, 33kHz, 83kHz.
- Output power: max. 10W, 10 levels adjustable, auto impedance matching.
- Direct connection voltage: max. 150Vpp.
- Overload and short circuit protection.
- HMI: 128X64 LCD.



- Power supply: 4 X built-in 18650 Li-on batteries, standard 7.4V, 6.8Ah.

1.3.2 Receiver:

- Input: Internal receiving loop, Clamp (optional), sensor (optional), fault locating A Frame (optional).
- Receiving frequency:
 - Active frequency: 640Hz,1280Hz,10kHz,33kHz,83kHz
 - Power frequency: 50Hz/60Hz,250Hz/300Hz
 - Radiation frequency passive frequency: center frequency 10kHz, 33kHz, 83kHz
- Pipe detection mode: wide peak method,narrow peak method,valley method
- Cable identification mode: Receiving Clamp (optional) intelligent identification and sensor (optional) identification
- HMI: 320X240 LCD
- Built-in battery: 2 X 18650 Li-on batteries, standard 7.4V,3.4Ah

1.3.3 Other:

- Volume: transmitter 270x220x85mm,receiver 700x270x120mm
- Weight: transmitter 2.2kgs, receiver 2.2kgs
- Charger: input AC 100~240V,50/60Hz,output DC8.4V,2A
- Temperature: -10-40°C,humidity 5-90%,elevation <4500m

1.4 DEVICE COMPOSITION:

1.5

1.5.1 Transmitter:

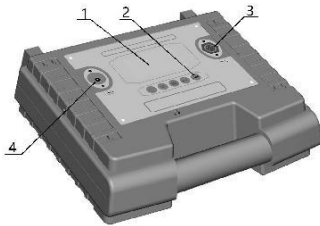

Fig.1.2 transmitter appearance

1. LCD display
2. Keyboard
3. Output port
4. Charge port

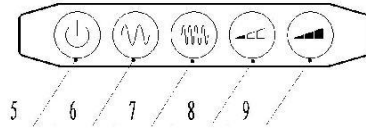

Fig.1.3 transmitter key buttons

- 5 Power on/off button
6. Frequency decrease button
7. Frequency increase button
8. Output level decrease button
9. Output level increase button

1.5.2 Receiver:

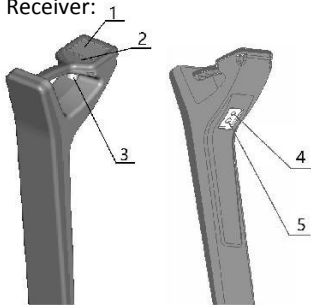

Fig.1.4 receiver appearance

7. LCD display
8. Key buttons
9. Gain adjustment knob
10. Charge port

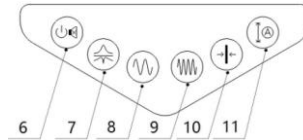
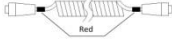





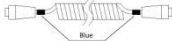





Fig.1.5 receiver buttons

1. Power on/off and mute button
2. Mode button
3. Frequency decrease button
4. Frequency level increase button
5. Set ref. button
6. Measure button
11. Accessories connect port

1.5.3 Standard accessories:

Item	Accessories name	Reference fig. And description	Qty
1	Transmitter output wiring cable		1
2	Transmitter direct connection adapt cable		1
3	Transmitter direct connection wiring cable		2
4	Grounding rod		2
5	Earth extension cable	-	1
6	charger	Standard one piece.	1

1.1.1 Optional accessories:

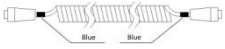
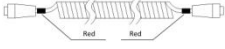
Items	Accessories name	Reference fig. And description	Qty
1	Receiver accessories connection cable		
2	Transmitter clamp		
3	Receiver clamp		
4	A frame		
5	sensor		
6	Pole sensor		
7	Pole sensor rod		
8	Long wiring cable for receiver accessories		
9	Long wiring cable for transmitter outputing		

10	Secondary charger :Matching it to charge the receiver and transmitter in same time	
----	--	--

2. COMMON SIGNAL OUTPUT MODE

This chapter mainly introduces the common signal output mode: Direct connection mode, Clamp coupling mode and Radiation mode.

In the following chapter 3, we will do detailed introduction.

2.1 DIRECT CONNECTION MODE:

This method is to connect the output cable directly to the metallic pipe and inject the signal. It adapts the water pipeline, gas pipeline, telecom cable, power cable, cathodic protection pipe testing point and other access points, and other line characteristics continuous metal structure.

Current from transmitter flows into the earth through pipeline access points, or distributed capacitance between earth and pipe, and at last return to the transmitter. This current on the pipe will generate electromagnetic radiation. Receiver will detect the pipe by receiving this magnetic field information.

Compared with other mode, this mode will get the max. transmission current for better testing result. We suggest to use this mode condition permit.

2.1.1 Direct connection mode connection diagram

*Noticed for the color correspondence! *Noticed to locking well all the plugs and sockets!

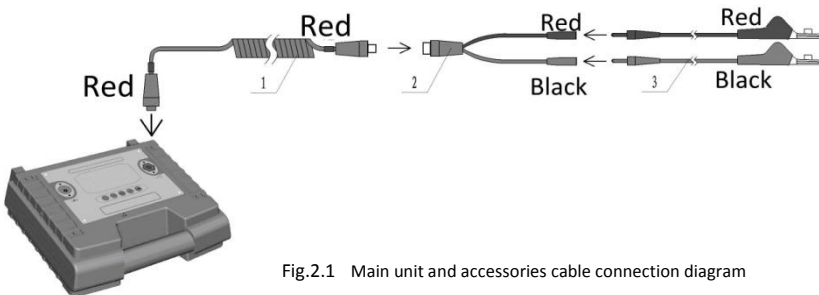
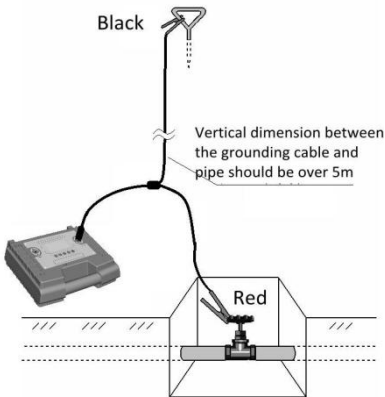

Fig.2.1 Main unit and accessories cable connection diagram

2.1.2 Direct connection mode wiring diagram



Connect the red alligator clip with the exposed metallic part of the pipe and connect the black alligator clip with the inserted grounding rod. If grounding cable is not long enough use the optional extending line.

Fig.2.2 Direction connection mode wiring method



- Grounding rod position should be over 5m from the pipe and try to make the black grounding cable perpendicular to the pipe direction.
- Don't clamp the black clip with the water pipe line or other pipe to avoid the interference to the target pipe detection.
- Use radiation detection mode to check whether other pipes below grounding rod and target pipe to avoid interference .
- Make sure well connection. If there're insulating coating or seriously rust on the pipe joint,to clean it before test to make sure well connection of red alligator clip and pipe metallic part.
- If different pipe sections are insulated,or it's insulation between pipe and fitting,the direct connection mode is unusable. Or to make the insulation parts electrical connection before testing. Checking the transmitter output current,if current is too small to test,it's possible that the pipe has insulation.

WARNING !
transmitter max. output voltage is 150vpp!don't touch the output clip and target pipe
when working!

2.1.3 Interface introduction and pipe voltage measurement

Long time press ON/OFF button  to power on the transmitter. Device will automatically check accessories and enter the direct connection mode.

Under this mode,the device will first test pipe voltage and display on the screen:

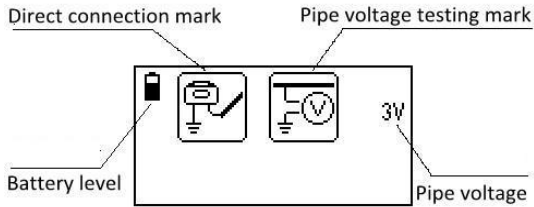

Fig.2.3 Pipe voltage measurement interface

If pipe voltage over limitation 50V,device will keep the voltage measurement interface and display the alarming mark as below:

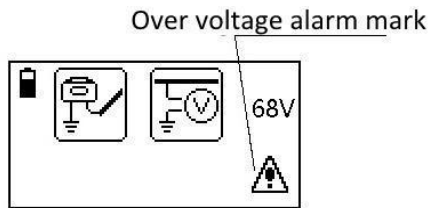

Fig.2.4 Over voltage alarming interface

If voltage is normal, device automatically outputs signal after several seconds. Screen display as below:

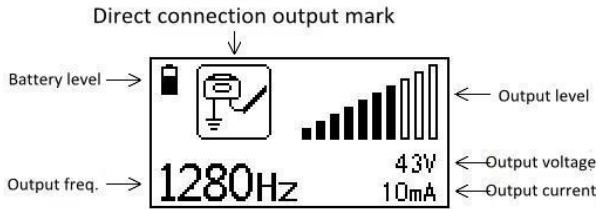



Fig.2.5 Direct connection output interface

2.1.4 Frequency selection



Press frequency decrease button  and frequency increase button  to select the transmitting frequency. Five frequencies could be selected: 640Hz, 1280Hz, 10kHz, 33kHz, 83kHz. Default power on frequency is 1280Hz.

Some selection suggestions:

- Common good grounding cable and pipe, suggest to use the default 1280Hz. It can complete most of the testing requirements.
- Choose low frequency such as 640Hz&1280Hz,to do long pipe route tracing. The low frequency has long transmission distance and not easy to induce to other pipe. And this two frequencies is complex frequency support tracing error/correct indication.
- Common pipe tracing use the middle-high frequency (10Hz). This frequency spread far and not easy to induce to other pipe.
- For high resistance pipe,such as the cable core with floating opposite end,pipe with anti-corrosive coating,cast icon pipe, we suggest to use high frequencies,such as 33kHz,83kHz. The high frequency radiation capacity is high but near transmission and easy to induce to other pipe.
- For normal detection we suggest to choose low frequency first.



2.1.5 Adjust output level

Press output decrease button  and output increase button  to adjust the output levels(total 10 levels). The right down corner will display voltage and current. Adjust output levels according different requirements:

- Big current contributes to detection stabilization and veracity.
- If high frequency(10kHz and above) and shallow depth (in 1 meter), high current output will bring receiving saturation distortion to make receiver nonlinear responding and depth measurement error. And now should decrease output level.
- Decrease output power is contribute to extend battery using time.

2.2 CLAMP COUPLING MODE:

This method is used for the naked Pipes while it is difficult or unable to reach the metal part, and both ends grounded, especially useful for the power cables.

Signal transmission of clamp coupling mode equals to a transformer: clamp magnetic core is transformer magnetic core,clamp internal winding equals to transmitter primary,pipe-earth loop equals to secondary (single-turn),transmitter offer primary current, pipe-earth coupling generate secondary current. The coupling current is related to the loop resistance.The smaller resistance the bigger current,the bigger resistance the smaller current,until it's too small to detect.

The clamp coupling mode is easy to use and no need electrical connection so no effect to pipe normal running and will reduce the induce to other pipe. But the coupling current is smaller than direct connection mode,require pipe both ends good grounding, this doesn't apply to all cases.

2.2.1 Accessories connection

Assemble transmitting clamp as

below:

Use the red connection cable to connect the clamp and the transmitter output port

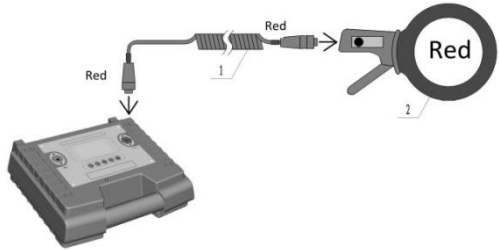

*well lock all the plugs and sockets

2.2.2 Clamp the pipe naked part as below:

Fig.2.6 Clamp coupling accessories connection diagram

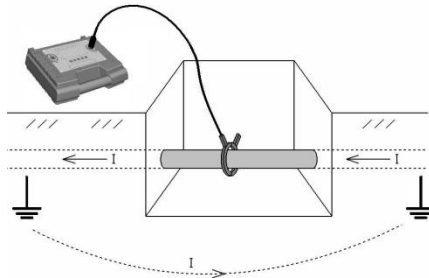

Fig.2.7 Clamp coupling mode wiring



- Make sure that the both ends of the pipe/cable are grounded. The grounding can be continuous grounding (shield grounding) or both-end grounding (high voltage power cable shield grounding at both ends).
- Different segment of the cable/pipe, or fitting with tube maybe insulated, we need to make them electrically connected, or we can not use this method.
- Judge whether it can induce signal on the pipe/cable only by the receiver detection result. If can not detect properly, we need to use other methods.
- Make sure the clip is fully closed when we use it to clamp the pipe/cable.

- Clear the Clip before using, to make sure there is no other things between or it is rusted.

2.2.3 Interface introduction

Transmitter power on and will automatically check the accessories and enter the clamp coupling mode. Screen display as below:

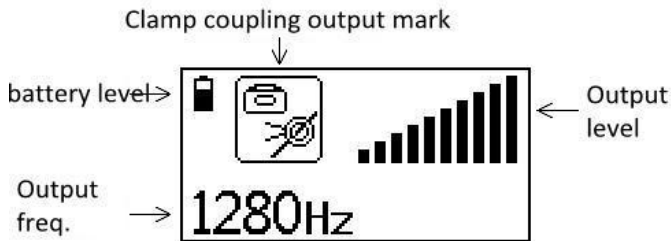



Fig.2.8 Clamp coupling output interface



2.2.4 Frequency selection

Press frequency decrease button  and frequency increase button  to choose the transmitting frequency.

Total five frequencies: 640Hz,1280Hz,10kHz,33kHz,83kHz.Power on default 1280Hz.

Clamp coupling mode frequency selection method is same as direct connection mode.

2.2.5 Output power adjustment

Press output decrease button  and output increase button  to adjust the

output levels(total 10 levels).

The current coupled to the pipe is much lower than direct connection mode,so to use the max. level output.

Clamp coupling mode can't display the coupled voltage and current.

2.3 RADIATION MODE:

If there is no bald part for the pipe, or detection before excavation,we need to use Radiation mode.

The Receiver use the internal radiation loop to radiate high frequency magnetic (primary), the metal tube-earth loop will induce current, and the induced current will radiate magnetic again (secondary), the receiver can receive secondary magnetic for the pipe detection.

The Radiation mode is easy to use and no cable connection is needed, especially useful for the detection of pipe that has no bald part. The disadvantage is that it has low induced current, specially if the pipe is deep (over 2m). And it will induce all the pipes so can not use this method.

2.3.1 Transmitter position

When use the radiation mode,no need to connect any accessories and device will automatically identify as Radiation mode.

For pipe route tracing: put transmitter vertically above the targeted pipe. Matched with receiver during the detection. Adjust the direction and location accordingly during the detection.

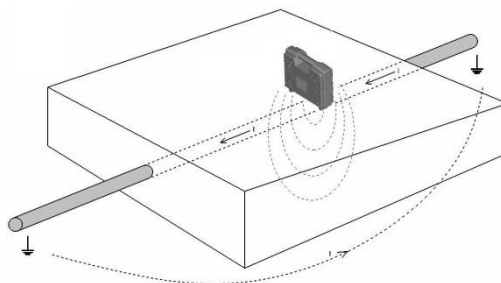

Fig.2.9 Radiation mode measurement diagram

For pipe detection: this needs two people to cooperate for the detection, keep the Transmitter and Receiver at certain distance and move them simultaneously, they should have same direction. Please refer to page 17 Radiation detection.



- Make sure that the both ends of the pipe/cable are grounded, or it can not induce signal. The grounding can be continuous grounding (shield grounding) or both-end grounding (HV power cable shield grounding at both ends).
- If the pipe is well insulated and it is not grounded at either end, we can not use the Radiation method. For example, some low voltage cables have no metal shielding, or the shielding is not grounded, we can not use this method.
- Can not put the Transmitter on the metal well covering or concrete with steel bar reinforcement, because the signal will be isolated by them.
- The transmitter will transmit signal not only to the targeted cable/pipe, but also to other medias, so we need to keep some distance between the Receiver and Transmitter.

2.3.2 Interface introduction

When transmitter power on, it will automatically enter the radiation mode if no accessories. Display interface as below:

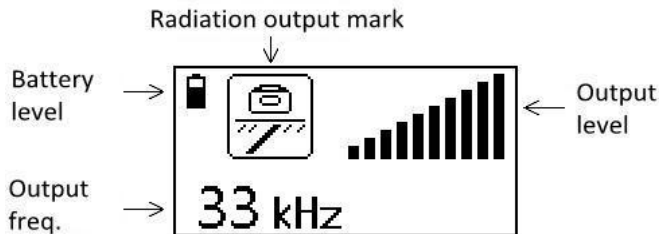



Fig.2.10 Radiation mode measurement diagram





Press frequency decrease button  and frequency increase button  to choose the transmitting frequency.

Total three frequencies: 10kHz,33kHz,83kHz.Power on default 33kHz.

Notice:

- High frequency has the feature of better induce effect, but short propagation distance and easy to induce signal to other pipe.
- Low frequency can propagate long distance,not easy to produce interference, but the induce effect is not good.
- For detection of high resistance pipe, we should select high frequency when it's difficult to induce suitable signal.

2.3.3 Power adjustment

Press output decrease button  and output increase button  to adjust the output levels(total 10 levels).

Use low output level will decrease to induce to other pipe and reduce the receiving-transmitting distance.

If detect deep pipe,we suggest to rise output level.

The transmitter can't test and display the pipe induced current value,so we have to repeated attempt according detection effect.

3. SIGNAL TRANSMITTING METHOD FOR CABLE DETECTION

The cable route tracing and the cable identification is very important function of pipe/cable detection. Compared with the single and continuous metal structure of pipe, the cable is composed by several cores and metallic armor. These construction and use

Email:salesmanager@grewin-tech.com Phone:+86-22-84943756

differences make signal applying method different and different connection method will make different electromagnetic field then different detecting result. So this chapter will introduce the cable detection signal transmitter method individually.

3.1 SIGNAL TRANSMITTING METHOD FOR DEAD CABLES

3.1.1 Basic connection method: Conductor-Earth

Conductor-Earth connection is the best connection method for route tracing and cable identification for dead cables. It will give full play to the device function and reach max. anti-interference performance. Refer below fig.3.1

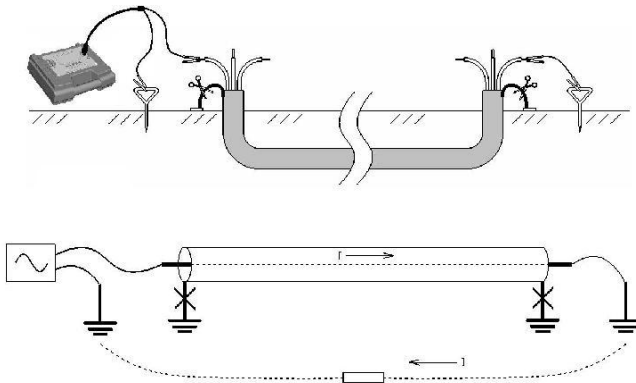

Fig.3.1 Conductor-Earth Connection Method

Loose the sheath of the both ends of the cable, also disconnect the earthing of Null line and Grounding line. Clamp one good conductor with the RED CLIP , and clamp the grounding rod with BLACK CLIP , connect the other end of the cable conductor to the grounding rod. At the cable opposite end, connect the core line with the grounding rod insert in the earth.



Attention: Use grounding rod, do not use grounding network! At least use grounding rod for the other end of the conductor, and the grounding rod should be away from the grounding network. Otherwise the earth wire back flow will effect the detecting result.

The current travels from the Transmitter, flows through the conductor and earth at the far end, then travels back to the transmitter. This connection method will make the receiver induce strong signal with clear character for device tracing error indication.

There will be strong signal flows through the well isolated conductor, it will not flow to nearby pipelines, especially the crossing metal pipelines, it specially applies to the route tracing under complex environment. In addition, the cable is grounded, so the signal voltage flow through cable is low, which can not interfere other instruments.

Because there is distributed capacitance between conductor and earth, the current will attenuate when flows from this end to the other end, but if it is well earthed, the leaked current will be very low, we can ignore it.

The shortage for this connection method is that it needs to disconnect the grounding line for the both ends of the cable and seems a little too complicated.

3.1.2 Sheath-Earth Method

As below Fig. 3.2 shows, loose grounding cable of the sheath of the near end of the cable, also loose the earthing of Null line and Grounding line of the low voltage cable, keep the sheath of the cable grounded at the far end. Then to apply signal between the sheath of the cable and the Grounding Rod (Do not use grounding network), and keep the conductor hung in the air. The current travels from Transmitter, then flows through the sheath and goes to the earth at the far end, then travels back to the Transmitter. This way, there will be no shielding, the signal to the ground is strong, and the signal character is clear. Also, because the distribution capacitance exists, the signal attenuates from the near end to the far end.

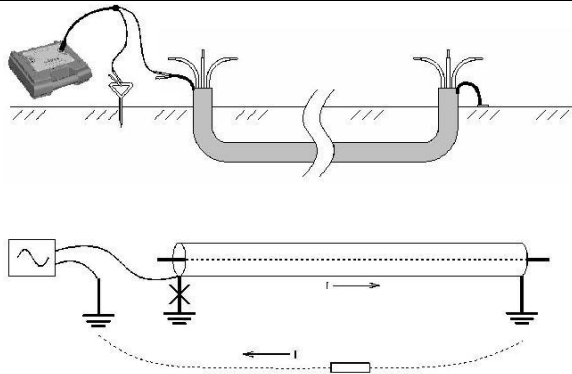

Fig.3.2 Sheath-Earth Method

The potential problem for this connection method is if sheath breakage, the current may go to the earth at the breakage point to make the signal received will have a sudden decrease at the breakage point, and the decrease level depends on the grounding resistance at the breakage point.

3.1.3 Phase-Sheath Method

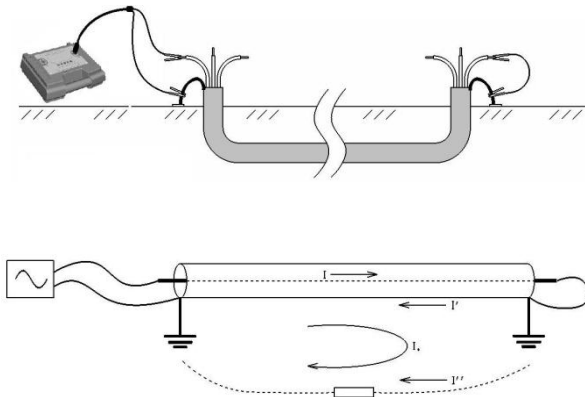

Fig.3.3 Phase-Sheath Method

As above fig.3.3 shows, signal is applied between cable one phase and sheath, short the far end phase and sheath, keep the both ends of the sheath grounded.

If there is one cable, the current will flow from the Transmitter to the conductor, and return through sheath and earth. Because the sheath has low resistance while earth has high resistance, most of the current will flow back via sheath and only little returns through earth. Because the direction of conductor current and sheath current reverse, the difference equals the virtual current which generates electromagnetic signal in external with some distance. The value equals the resistance current back through the earth. Because the induction of Conductor-Sheath loop and Sheath-Earth loop, the current will also be generated by electromagnetic. The end effect is the virtual current equals the vector addition of earth loop resistance current and induction current. For different field condition, the virtual current is about only a few percent to lower than twenty percent of the injected current.

If there're other same path cables (with same end positions), the return current will be shunted by these cable sheaths. For example, if there're three cables in same path, the sheath return current of every cable is $\frac{1}{3}I$. The virtual current is positive and the value is about $\frac{2}{3}$ of the injected current, while the nearby current is passive and value is about $\frac{1}{3}I$. Refer below Fig. 3.4

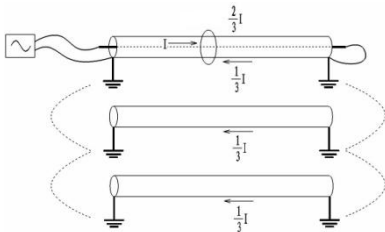

Fig.3.4 External effect: $\frac{2}{3}I$

The Phase-Sheath method is easy to connection, no need to loose the grounding cable. But when multiple cables lay in same path, the signal difference of different cables will not quite different not easy to distinguish only by signal amplitude.

When single cable lay, the effective current will sharp decrease, signal will be weak and effective current has induction current so the target cable has same induced signal phase with nearby pipes. If use the complex frequency, it maybe difficult to eliminate the disturbing signal according the current direction.

3.1.4 Phase-Phase Method

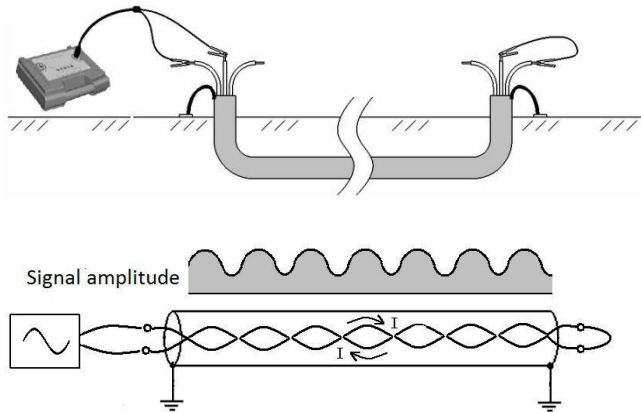

Fig.3.5 Phase-phase method

As above fig 3.5 shows, the signal is injected between two phases of the cable, and the two ends of cable short circuit. The two phases of cable is interior twisting, so the current value is same but in opposite directions. Though the two phases are near each other, the distance of two phases and receiving coil is small difference, and the magnetic field direction here will have opposite direction. But the magnetic field strength is not same because the distance difference, so most parts will be counteracted. The balance parts will be weakened by the metallic sheath shielding effect and at last received by device. Because the twisting, signal will travel long with the cable path and with period and direction variation.

In one twisting period, the external radiation flux will be fully cancelled out by the 360° continuous change, so no induced current in the sheath-earth loop.

Because the effective signal is very slight, use high frequency will be easier to detect than the low frequency. The phase-phase connection method can't use the current direction test method of receiver to eliminate nearby pipeline interference.



3.1.5 Select frequency

- Normally, use the default 1280Hz can fulfill the detection of most of the cables/pipes except phase-phase connection. It's low frequency and with long transmitting distance so not easy to induce to other pipe. Also the receiver has better receiving effect for this frequency.
- For long distance cable/pipe (longer than 2-3Km), if use the 1280Hz, there will be very big attenuation if long distance. So we suggest frequency 640Hz.
- 640Hz and 1280Hz is complex frequency, under this two frequencies, device support tracing right/wrong reminding.
- For phase-phase connection, we should select high frequency (10kHz,33kHz or 83kHz).

3.2 SIGNAL TRANSMITTING METHOD FOR LIVE CABLES

3.2.1 clamp coupling method

This is an ideal detection method for the live cables, no need to change the cable and very safe to operator; there is signal on the whole length of the cable, and no distance limitation.

The both ends of the cable sheath should be grounded, or the coupling current will decrease while grounding resistance increases.

We can not use the clamp coupling method if the both ends are not grounded, or the sheath is broken.

- Clip the cable

As below fig.3.6 shows, this method is useful for the detection of common three-phase power cable. Connect transmitter output with clamp and use the clamp to clip the cable (not clip the part above the grounding line). The clamp equals to transformer primary, cable metallic sheath-earth loop equals to secondary (single-turn). The coupling current is related to the loop resistance. The smaller resistance, the bigger current.

The cable current from clamp coupling is small. To strengthen detection effect, we suggest choosing big output level.

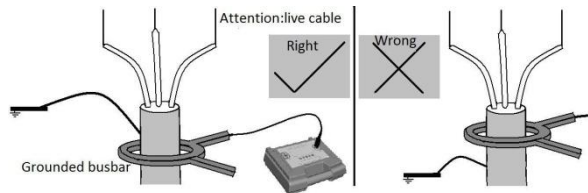
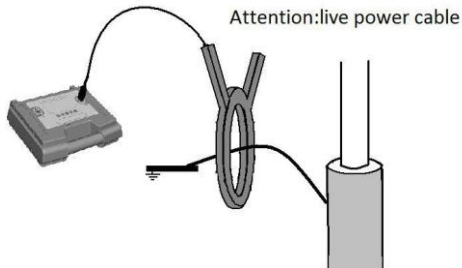

Fig.3.6 Clamp coupling method 1 (to clamp the cable)

- Clip the cable sheath grounding line

This method is useful for detection of ultra high voltage single core live cables. Because it has strong power current flows the cable phase, and it has no three phase offset effect like the three-phase cables. If we clamp the cable itself using the Clamp, it is easy to have magnetic saturation and signal is not transmitted. That is why we need to clamp the sheath grounding cable.

Such single core cable sheath will crossing connect at some distance, the signal also will flow from one phase sheath to another sheath. Notice it when detection. For three cores belted cable, if not suitable to clamp the cable, clip the cable grounding line is also useful. But during some special situation, this will make signal feature unpredictable variation.



3.2.2 Null line/Ground line/Shield Injection method

This method is used for detection for the live low voltage cables, because most of the low voltages shield is not grounded, or the shield is not continuous, or it is not very well grounded, we can not use Clamp Coupling method.

This method no need to modify the cable, and because inject the high frequency, it will not effect the running line.

At the operator end, clip the null line, grounding line or shield with the red clip, and the black clip to the grounding rod. It is as Fig. 3.8 shows.

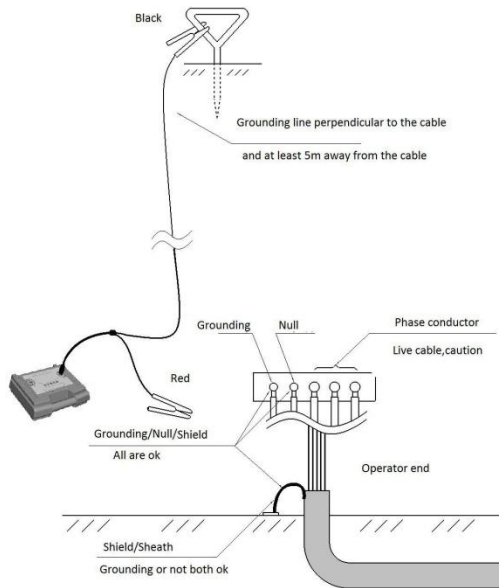

Fig.3.8 Null / Ground / Shield Injection Method



- The cable is live, there is power, the operator needs to be competent to do this work for cable connection.
- Please do not connect the Transmitter at the operator end. If inject signal in the transformer end, signal will be injected in all the outlet cable and difficult to distinguish the target cable.
- The position of the ground rod: it should be at least 5m away from the pipe or cable, and keep the black cable perpendicular to the suspected pipe path.
- If the null cable is not grounded at the operator end, please preferentially use Null to inject signal.
- The shield maybe discontinuous for the low voltage cable, if the signal injected is too weak, or the signal is interrupted during the detection, we can

use the Null/Ground method to inject signal.

- When we detect the live high voltage cable, the signal is very weak or we can not receive signal using clamp coupling method, this shows that the shield ground resistance is too high at the double ends, for this condition, we can use Shield to inject the signal.
- For single conductor ultra high signal live cable, sometimes the clamp coupling method maybe not effective, we can use Shield Injection method.

4. PIPE ROUTE TRACING

4.1 PIPE ROUTE TRACING (PATH TRACING)

4.1.1 Select the proper signal transmitting method

Choose proper method to inject signal to the target cable according the description of chapter 4&5

4.1.2 Use the internal loop of Receiver to trace the pipe

It is not necessary for the Receiver to connect any external sensors for the tracing, the default is Internal Loop Induction method.

4.1.3 Receiver interface introduction

Long time press On/Off/Mute button  , power on the receiver. Screen display as below:

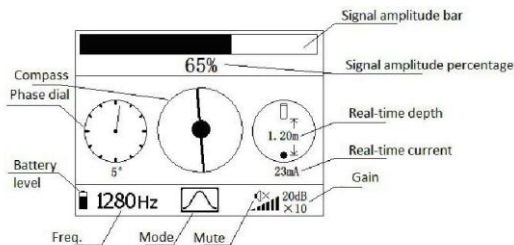





Fig.4.1 Pipe detection interface diagram

4.1.4 Setting receiving frequency

Press frequency decrease button  and increase button  to select the receiving frequency. Make sure same transmitting and receiving frequency.

Total 10 frequencies/frequency bands for selection: 640Hz,1280Hz,10kHz,33kHz,83kHz, power frequency 50/60Hz, power frequency harmonic 250/300Hz, RF 10kHz frequency band, RF 33kHz frequency band, RF 83kHz frequency band. Default 1280 Hz.

4.1.5 Select mode

Press Mode button  to choose wide peak mode, narrow peak mode, null mode or history curve mode.

- Wide peak mode:

In the wide Peak mode, the signal right above the cable/Pipe is the strongest. The advantage for this method is with high sensibility, and wide range; the disadvantage is that it responding curve changes slowly, and not easy to tell the parallel cables.

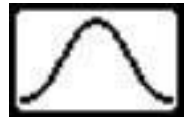

- Narrow peak mode:

Similar to the wide Peak method, it has sharp responding curve easy for parallel cable/pipe detection; the disadvantage is that it has low sensibility.



- Null mode:

The signal just above the cable/pipe is weakest, and it changes rapidly besides the cable/pipe. The advantage of this method is



that it is easy to precisely pinpoint; the disadvantage is that it has low anti interference ability.

- History curve mode:

Record the signal amplitude history curve under the wide peak



mode. It will record and distinguish the signal variation along

mode mark with time-varying. It applies to phase-phase short circuit fault detection.

Fig.4.2 Different

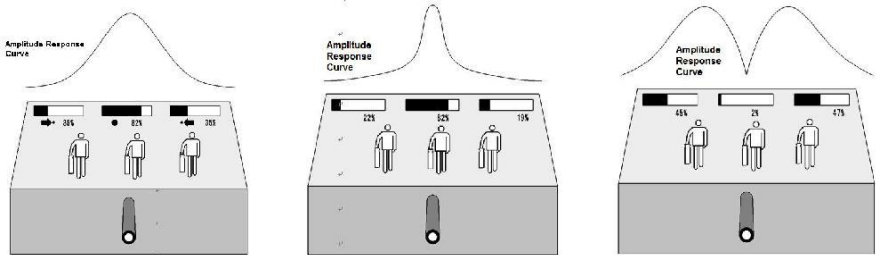



Fig.4.3

4.1.6 Adjust gain

Signal responding under different mode

Press Gain button to display  on the up left corner to do automatically gain adjustment. It means the current signal amplitude is automatically adjusted to 60%. Basic on the auto gain, it's also support manual gain adjustment. Turn the knob to do fine adjustment, and there will be gain value and actual multiple display on the bottom right corner.

4.1.7 Pipe tracing according signal amplitude (traditional method)

We need to begin to locate the pipe at the Transmitter side but not be effected.

- Use the clamp method and radiation method. The transmitter will interfere the detection if the distance is too near, so we need to keep some distance. The interfere is related of the transmitting power and frequency. The bigger power and frequency the stronger interfere.
- Narrow peak mode:

The minimum distance between the Transmitter and Receiver needs to be determined by experience, normally 5m for the Clamp method and 20m for radiation method.

Use the Peak mode (Wide Peak or Narrow Peak) to find the point where signal is strongest, and begin to trace the cable/pipe at this point. Swing the Receiver, the signal amplitude will change as Fig. 4.2 shows, follow the peak position (highest

point at Peak mode) or null position (lowest point at Null mode), till we get the route of the cable/pipe.

Use Null mode, we can quickly locate the trace, the weakest point is right above the pipe, at the both sides of the cable/pipe, the signal will increases obviously. But because Null mode is easy to be interfered, we need to change to Peak mode after some time to ensure the tracing result.

4.1.8 Compass oriented quick tracing method (new method)

When transmitter near the pipe above, compass in the middle of screen will directly display the pipe position below the receiver and with a middle arrow points to the pipe. If receiver right above the pipe, the arrow will change to a dot. This function will do quick trace for the underground pipe.

Check The arrow direction, if arrow points to right it means the cable is in the right position and should to move to the right, otherwise move to the left. If arrow changes into dot and arrow direction changes even left/right move a little , the receiver should be right above the pipe.

Attention: If weak signal or high interference maybe no dot appears. Then should consider the arrow direction variation.

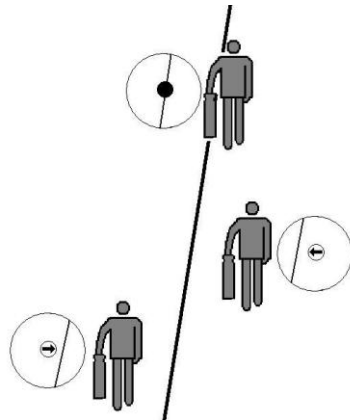

Fig.4.4 Compass function demonstration



- Now matter faced to the pipe end or transmitter, the arrow will all point to the pipe.
- If nearby pipe has strong signal, and the receiver is near, compass still indicate but please notice, this will display the nearby pipe but not the target pipe.
- If nearby pipe has large interference, the compass will has deviation. If need accurate position, please refer below the 3rd segment Accurate positioning.



4.1.9 Anti error tracing (Correct/ Error tracing)

The nearby pipe usually has lower current than the targeted pipe when detecting, but the response of the Receiver also has some connection to the depth of the pipe/cable, if the targeted cable/pipe is deeper than the nearby cable/pipe, it will be difficult to tell which one is having lower current.

Through test the current phase position will have correct/error indication and achieve the Correct/Error tracing function.

Use the Correct/ Error function, the work frequencies should be 640Hz/1280Hz. If use other frequencies, the device will not display the phase dial.

When we use Correct/Error indication function to detect the cable/pipeline, the Receiver will real-time measure the current phase, and compare it with the reference current phase. This process of measuring and recording current phase is called Set Reference. This value will not be lost even the Receiver is switched off.

On the position near transmitter but not interference (for example,5-10m distance), detect the target pipe position. Above the pipe back on the transmitter and face to the pipe end, press Set Ref. button  the flash indication will appear on the top left corner  to check whether need to do phase zero set. If press other

button to exit, if press Set ref. button again it will display  to prompt set reference finished and current phase zero. Now the phase dial pointer point to the right above and the degree under dial become to 0°. The current phase measurement after set reference take this as standard.

If need to detect other pipe, should to set reference again.

During the process of detecting pipe, check phase dial and if almost the pointer points above, it means device above the target pipe. If pointer always points to below and appear '?' mark, it means tracing nearby pipe. Refer below Fig.4.5

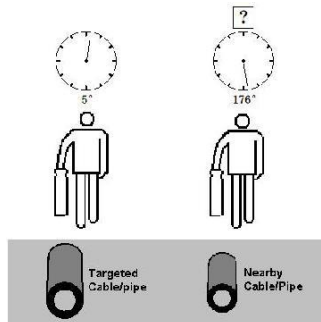

Fig.4.5 Correct/ Error indication

The nearby pipe signal amplitude maybe big or small and also will have compass indication.

If extra-long pipe, because the distributed capacitance, the phase deviation will gradually increase. If reach some value and effect judgment (such as 45°), it's suggested to set reference again above of the target pipe to make phase pointer back to right above again.

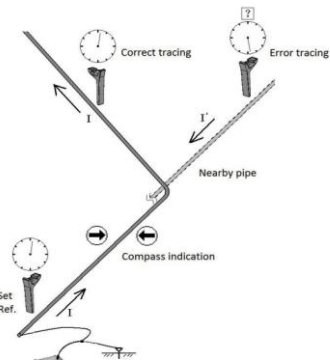



Fig.4.6Intelligent tracing demo.

The process of Correct/Error indication as below Fig. 4.6



4.1.10 Use audio for tracing assistance

The speaker will output audio to real-time reflect the current signal strength. It's some help for the tracing. But we still suggest the compass function to do a quick pipe tracing.

Press Power switch/ mute button  to open or close the speaker. The power on default mode is speaker closing.

4.2 ZONE DETECTION

In order to avoid the damage of the cable/pipe, we need to detect whether there is unknown cables/pipes in this area before excavation. For the area detection, we can use

Passive Detection and Radiation methods.

4.2.1 Passive detection

For Passive detection, the Transmitter is not necessary. Adjust the frequency of the Receiver to Power or Radio, and the Receiving mode is Wide Peak or Narrow Peak. Then search the area in grid and observe the history curve, there will have amplitude response on above the cable/pipe, record the result and mark on the ground. Refer Fig. 4.7

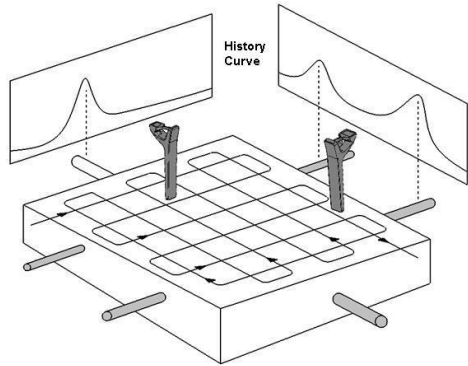





Fig.4.7

Power method: the Receiver will receive the power or 5th harmonic signal magnetic radiated by the

Passive zone detection

cable/pipe, this is especially useful for the detection of live power cables. Part of other cables/pipes can also be detected using this method because of the existence of power induction current. So we can not say that the cables detected using Power Method are all power cables. Power frequency receiving frequency is 50Hz and 250Hz, or 60Hz and 300Hz. It will be different if different countries or zones. We also offer customized , refer the part Before using.

Radio method: the pipes can receive the radio magnetic and secondarily radiate it again. So we can use this method to detect part of the cables/pipes that has no power current.

For different signal, the radio frequency has three frequency brands, 10KHz  ←10k→ , 33KHz  ←33k→ and 83KHz  ←83k→ .



- Using Power or Radio method for receiving, except the power frequency fundamental frequency, device doesn't support compass indication and real-time depth measurement.
- In passive detection, the adjustment of gain is very important. The response is strong even if the gain is low when the signal is strong; but it needs to tune to high level if the signal is weak. The strong signal pipe detection will distortion under high gain, but it can be suppressed after checking the marked sign.
- Please note that whether it is Power or Radio, we can not ensure all the cables/pipes can be detected.

4.2.2 Radiation method

For this method, we will need the Receiver and Transmitter, and at least two operators. Please make sure the target zone and the possible directions pipe crossing, set the working mode of the Transmitter to Radiation, and select same frequency for the Receiver and Transmitter. One operator controls the Transmitter and one operator controls the Receiver, keep the direction of the Transmitter and the Receiver perpendicular to the cable/pipe. The two operators should keep distance for 20 meters, and move simultaneously at the direction perpendicular to the cable/pipe. When the Transmitter passes the cable/pipe, the signal will be inducted into the pipe and the Receiver will receive signal. Observe

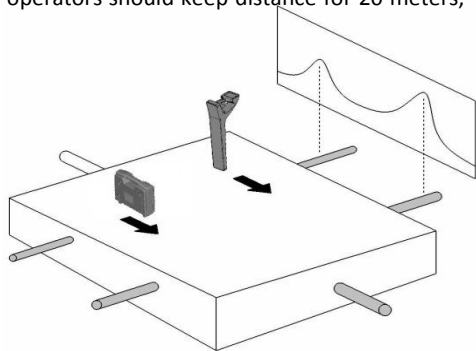

Fig.4.8 Radiation zone detection



the receiver responding and mark on the ground when peak responding above the pipe.

Refer Fig. 4.8

After detecting the area in one direction, the operators needs to exchange the position of the Transmitter and Receiver, and search the area again in opposite direction.

If possible, the operators need to detect the area at all possible direction.

Mark all the positions of the cable/pipe, put the Transmitter above the pipe, use the Receiver to trace each cable/pipe.

Radiation method is the most reliable method for area cable/pipe detection, but limited to the radiation method itself, i.e., the cable/pipe must be grounded and the concrete with metals can not use, we can not ensure that all the cables/pipes can be detected.

4.2.3 Comprehensive Detection

Different detection method has its advantage, but it also has its limitation, the operator needs to try more methods to ensure the reliability.

4.3 PRECISE POSITIONING

Compass method will have deviation if interference or nearby pipe effect.

If need o do the following to increase the location accuracy, we suggest to use below manual measurement method by PEAK or NULL method.

- Keep the Receiver perpendicular to the suspected cable/pipe, find the position where there is strongest response.
- Don' t move Receiver and rotate it, to find the angle that has the strongest response.
- Keep the angle, move the Receiver left-right, find the point has the strongest response, mark it.

Repeat the above steps if possible to improve accuracy. Refer below Fig. 4.9

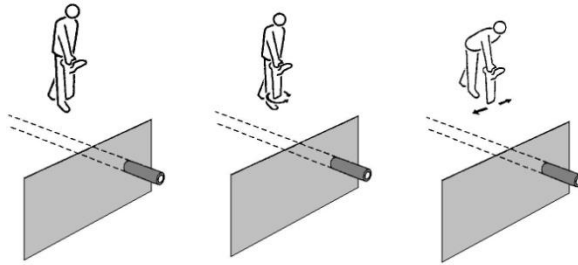

Fig.4.9 Precise positioning

Use the Null method to find the point where has weakest points, and mark them.

If the positions we get using Peak or Null are the same, then the positioning is accurate.

If not, it shows that there is nearby cable/pipe interference, we need to do the correction.

In Fig. 4.10, the Null position and Peak position is at one side of the cable/pipe, while the actual position is at the other side, it is at $L/2$ position to the Peak position.

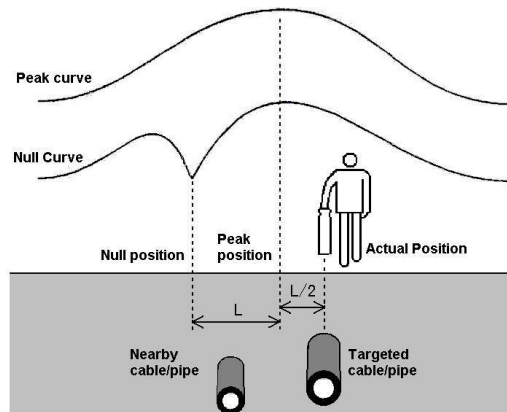

Fig.4.10 Positioning correction

4.4 DEPTH MEASUREMENT

4.4.1 Auto measure the depth and current

When the receiver distinguishes the position mainly above the pipe, press to do real-time depth and current measurement. Display as below:

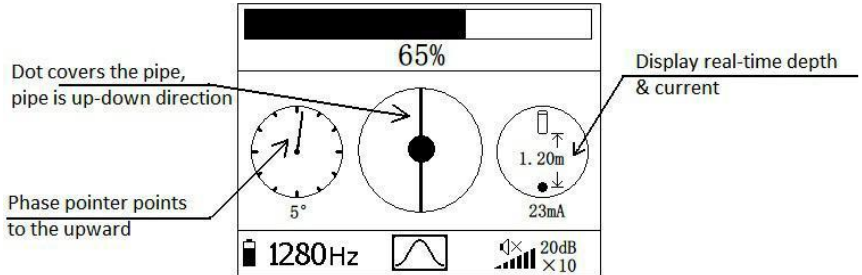





Fig.4.11 Real-time depth and current measurement

- There's a dot in the middle of compass position and the dot covers the pipe, it means the receiver is mainly directly above the pipe.
- Pipe is mainly up-down direction, it means the detection direction is mainly conform with the pipe direction.
- The phase dial direction is not the prerequisite of real time depth. But when under the 640Hz & 1280Hz frequencies, the phase pointer points to upwards means correct tracing and above the target pipe(not above the nearby pipe). Under other frequencies there's no phase pointer. When it deviates the pipe right above, the real time depth and current display will disappear.
- If screen upper right display  , it means transmitting signal is too strong and receiver saturation distortion. Press  button to reduce the output level. If saturation distortion, the real time depth measurement and press depth measurement are all invalid.
- Set depth unit as m or ft (Check P1 before using).

To get a more accurate and stable testing result, press measure button  to do long time average measurement. Press measure button and screen will display waiting mark , about 2 sec. Later it will display the measured result and disappear after 2 sec. Display as below Fig. 4.12

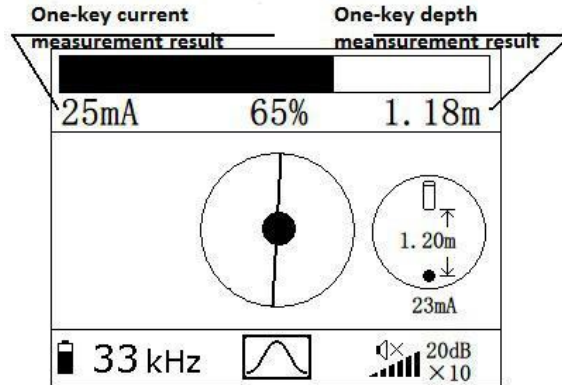

Fig.4.12 One-key depth and current measurement



- Loudspeaker output will have slight interference to the real time depth measurement. So if possible, please make it mute.
- To verify the depth: put the Receiver on the ground, and measure it, put the Receiver 0.5m to the ground, if the depth difference is within 0.5m, then the measurement is correct.

When passive detection(except the power fundamental frequency), we can do real time depth and current measurement. One-key measurement is

- If use Radiation method, the accuracy will be lower than the Direct Connection method or Clamp Coupling method. If must use Radiation method the distance between the Transmitter and Receiver should be at least 20m.
- Try not to measure near the turn or T joint as possible, at least 5m far from it



RCI-600P Pipe Locating System

- The measured result is from the bottom of the Receiver to the core of the cable/pipe, please note that the whole cable/pipe is nearer, especially when the cable/pipe diameter is big.
- Nearby pipe interference will make the depth measurement deviation increase, even not reliable. Then we can use the accurate locating to distinguish whether it's possible to use the auto measurement. If the peak point is coincident with the null point, the depth result is credible. If not, there's nearby pipe interference. And the data bigger, the measured deviation is bigger.
- Use the current to help us to analyze the cable/pipe condition. If we apply a signal to the targeted cable/pipe, the current will decrease as the distance increases, this is normal. But if there is a sharp decrease, it may have the following reasons: one is that there is a T joint the current is shunted. Another condition is that there is some damage to the shield.
- The current value measured above is based on the depth is correct, if the depth is not correct, the current will not be applicable.

Specially notice that in most of the strict pipe detection, no matter use any brands devices, it is not suggested to use the auto depth measurement result. Though real time depth and one-key measurement is convenient, and even result is almost fulfill requirement when little interference or not very complex environment, the result is only for reference.

4.4.2 45% null manual depth measurement

Use the Null method to find the point A in the pipe with weakest signal, and then incline the receiver for 45° to move to the other side until find other weakest point B.

Incline receiver to the other direction with 45° to find another weakest point C. Common, depth equals to AB or AC. The nearby pipe interference may make the null value position not right above the pipe, so it's more accurate to use the value that half of BC as the depth value.

Please notice, when incline the receiver, pay attention to the receiver marker line. When one marker line is parallel to the earth and the other line is perpendicular to the earth, the receiver inclines for 45° .

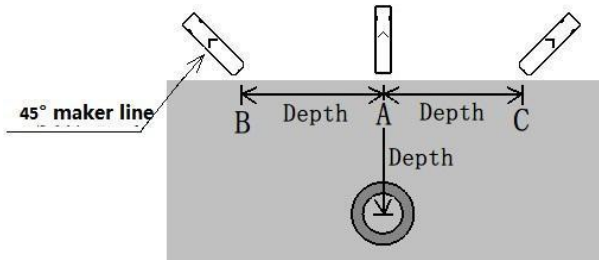

Fig.4.13 45% null manual depth measurement

4.4.3 80% wide peak manual depth measurement

Use the wide peak method to find the point in the pipe with strongest signal. Press Gain adjusting button to set the auto gain

adjustment amplitude as 60%. And left-right horizontal move the receiver to find two points which signal amplitude reduced to 48%, the distance between this two points is the pipe depth. Refer below Fig.4.14

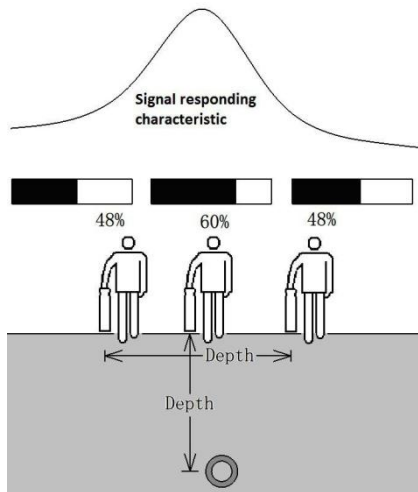

Fig.4.14 80% wide peak depth measurement

5. CABLE IDENTIFICATION

In the power construction, the cable identification is a work with very strict requirements, because it is related facilities and personal safety. There are three methods: Clamp smart identification, Clamp current measured identification, and sensor Identification.

5.1 CLAMP SMART IDENTIFICATION

Clamp smart identification is the clearest, the most powerful anti-jamming method.

5.1.1 Signal transmitting method

- The frequency of receiver must be settled as 1280 Hz or 640Hz. The fault frequency, 1280 Hz, can meet the most test requirement. If the cable is too long, you can use 640 Hz.

For dead cable, you should select the direct connection method, and the best connection is core- ground connection; If it is not convenient to connect the cable, you also can use phase to sheath connection, don't use sheath to ground connection.

- For running cable, the best choice is clamp coupling method, if it can't be used, you should use with caution null line/ grounded line/ sheath injected method.
- We can not use the radiation method to transmit signal.

5.1.2 Accessories connection

Assembling the receiving clamp: 1: receiver accessories connection line(blue); 2: receiver clamp (blue).

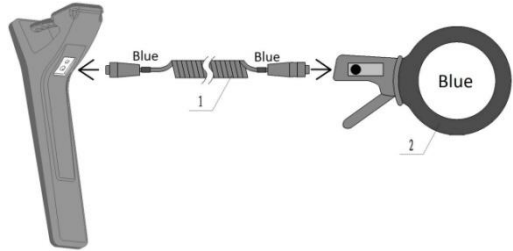

Connect it as Fig.5.1:

5.1.3 Receiver interface introduction

Power on and the receiver will automatically identify the connected accessories and set as Clamp receiving mode as below:

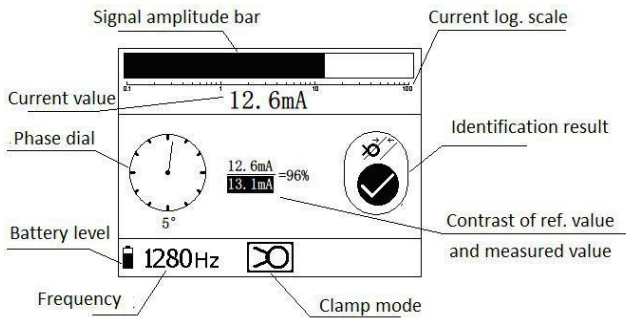



Fig.5.2 Clamp identification interface

Receiver default frequency is 1280Hz, we should set it same as transmitter. Under the clamp mode, we don't need to adjust the gain and device will directly display the current value and show it's percentage result with set reference current. Phase dial will display

the current phase. The identification result will display Correct  or Error .

5.1.4 Set reference

Use the Set. Reference method, we first need to measure the target cable current intensity and phase in known position as reference. Compare the measured result of some point with this reference result to distinguish. The process of measurement and record the result of current and phase is called Set. reference.

The setting reference should near the receiver, and not be interfered by it. When using clamp coupling method to transmit signal, it should be leave the transmitting clamp at least 2m. The receiving clamp should lock the target cable. **The direction arrow of clamp should point to cable terminal.**

Press the “Set Reference” button  of receiver, the

screen will show:  on the left top corner to check whether to do clamp set

reference. Press other button to cancel while press Set reference button  again to

finish setting and now screen will display . Now the current phase returns to zero,

pointer of phase dial points upward a, angle below dial will be 0° and at the same time the current value will be the compared and calculated denominator (reverse showing) .

The indicate result sll be correct as .

This will be the benchmark for following identification. After setting reference, the data should be saved. If the instrument power off, the data should not lost. When identifying other cable, the reference must be reset for the new target cable.

5.1.5 Identification

Leaving the reference point, arrive at the identified point, then using the clamp to lock the cable. **Pay attention that the direction arrow of clamp should point to the cable terminal.** If the locked cable is the target one, the current intensity and phase of measured point will be similar with the reference point. If it meets the following

standards, it will be the target cable:

- The current value is greater than 75% of reference value, and less than 120%.
- The phase difference of current doesn't exceed 45°.

Then the identification result will be

correct ✓

If it doesn't meet above standards it is the neighboring cable, the identification result will error ✗

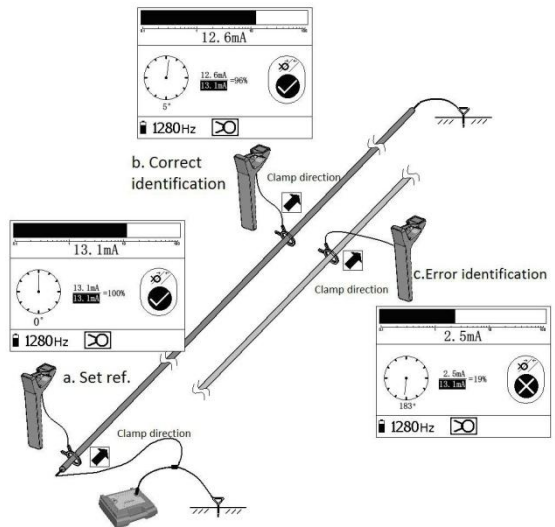

Fig.5.3 Clamp identification process



- When setting reference and identifying, the direction arrow of receiving clamp must point to cable terminal and be closed well.
- The connection of core wire to ground is very complex, but the effective current in the target cable is the most, and less susceptible to interference by neighboring cable. Priority should be used. Example: current of target cable is I, phase is at 0° vicinity, identification is correct; current of neighboring cable is much less than I, phase is near 180° or unstable, identification is error.
- When transmitting the signal with phase to sheath connection, if no parallel cable, the effective current of target cable will be smaller; if have, the effective current of target cable will be the sum of other cables.

- Example A: the path of 3 cables is same (including the target cable), the test result is: the current of target cable is I, phase is at 0° vicinity, identification is correct; the current of two neighboring cable is $I/2$, the phase is at 180° vicinity, identification is error (as shown in Fig 3.4)
 - Example B: the path of 2 cables is same (including the target cable), the test result is: the current of target cable is I, phase is at 0° vicinity, identification is correct; the current of neighboring cable is I, the phase is at 180° vicinity, identification is error. Because the current is same, the identification is only by the phase, and also should pay attention the clamp direction
 - Example C: the cable is parallel with the target cable, but the path is not same (generally, the terminals are in different position), the test result is: the current of target cable is I, but the value is smaller than injected, phase is at 0° vicinity, identification is correct, the current of neighboring cable is near to 0, phase is near to 180° or unstable, identification is error (as shown in Fig 3.3).
- If transmitting the signal with sheath to ground connection, if the insulating sheath was damaged, the current after the damaged point will be reduced. It will effect your judgment with current intensity criterion. So, not recommended.
 - If transmitting the signal to running cable with clamp method, the transmitting clamp will radiate signal to space, and it will interfere receiving. So, when setting reference, the distance between transmitting clamp and receiving clamp must be 2~5m. Method to judge whether interfered: setting

reference first, then unlock the cable and close the clamp in air at the same position. Observing the measured current value, if the value is much less than the reference and near to 0, that means the distance is enough; otherwise, should continue to increase the distance.

- If transmitting the signal to running cable with clamp method, the both ends of cable must be grounded well to form a larger coupling current. If the active current is small, check whether clamped the target.
- This method can't be used to identify single core UHV running cable. Power current through such single core cable is powerful, and no three cores cable phase offset effect. If clamp the cable itself, it's easy to make clamp magnetic saturation and can't receive the high frequency signal.

Safety Warning!

- As the cable identification involves facilities and personal safety, first, according to various on-site information (such as cable diameter) to exclude the good cable based the test result. The remaining should be analyzed enough according to the current intensity and phase of parallel cables, and then judged.
- The right judgment is based on the right operating. So must verify the connection and setting reference is right. .
- If two or more cables show identification right or wrong, and the difference of current value and phase is little, you must pay more attention, don't jumping to conclusions. The problem maybe the connection of transmitter, so you should first check the following error:
 - Forgot to set reference or set wrong.
 - The clamp direction reverse.
 - In identifying, not lock target cable, and only lock neighboring cable.
 - The transmitting method is wrong.
 - The clamp jaws not clean.
- If not determine yet, please using other method.

5.2 CURRENT MEASUREMENT BY CLAMP

Except the 640Hz and 1280Hz, other frequencies only support current measurement but can't measure the phase or set reference. So can't use the intelligent identification. But we still can use the current value to distinguish.

For 10kHz,33kHz, and 83kHz, because the frequency is very high, the signal leakage through the distributed capacitance is very big, so the measured current value will gradually reduced following with the increasing of distance.

The signal injecting method of clamp current measurement and attention matters are similar as intelligent clamp method.

Preferentially adopt the intelligent identification and the current measurement method is only a auxiliary method.

5.3 SENSOR IDENTIFICATION

When the field condition is that there are many cables and they are too close, and we cannot use the clamp to clip the cables, we can use the sensor method.

5.3.1 Accessories connection

Sensor accessories assembling method: contact the receiver accessories connection cable (blue mark) with sensor and receiver accessories input socket. Refer below Fig. 5.4

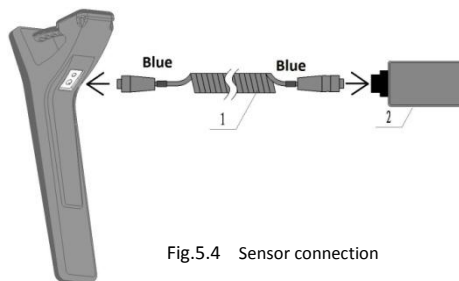

Fig.5.4 Sensor connection

Please notice,sensor is used in the buried cable. Some bridge cables not suitable to

direct contact can use the rod sensor.

5.3.2 Interface introduction:

After sensor connection, when power on the receiver will automatically recognize the connected accessories and set as Sensor receiving mode. Reference interface as below

Fig. 5.5:

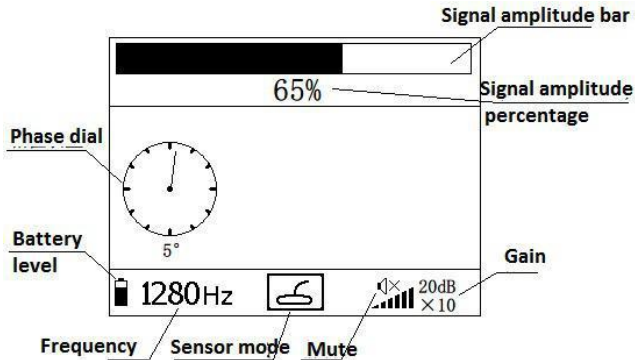

Fig.5.5 Sensor identification mode interface

Sensor is to put the detection coil external, the operation is same as use the internal coil. Put the sensor close to the targeted cable, and keep max. distance possible to the nearby cables. There will be larger responding in the target pipe but small responding in the nearby pipe. Use the signal amplitude value, we can distinguish manually which one is the targeted cable.

Sensor identification method can be used in all the frequencies. When choose 640Hz and 1280Hz, it supports current phase measurement and use the anti error tracing function. Please notice the arrow on the sensor should point to the cable terminal.

In the near-end of transmitter, put the sensor close the the target cable, adjust to suitable gain and don't adjust gain again during the detection of unknown point. This will quickly identify and improve accuracy. Refer below Fig. 5.6

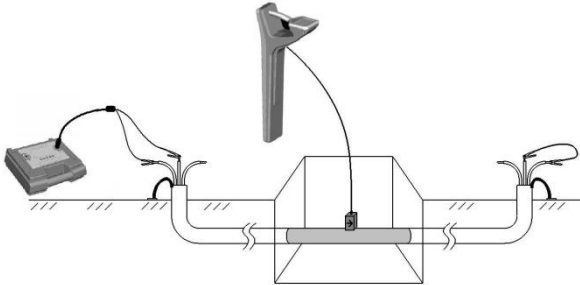

Fig.5.6 Sensor identification

Use the Sensor method for cable identification, we should preferably use phase-phase connection, and short the two phases at the far end if want to get most accurate conclusion.

Find the cable with strongest signal, we can move the sensor around that cable one circle. Because the two phases are shorted,there should have strong and weak changes for the signal, while the nearby cable doesn't have such character. It is as Fig.5.7 shows, this way we can do the confirmation.

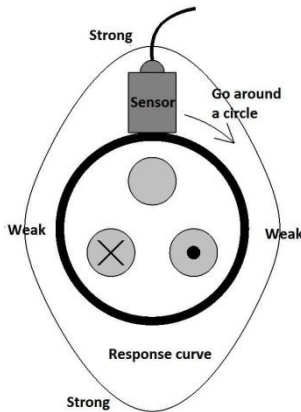

Fig.5.7 Sensor measurement for one circle

6. PINPOINT FOR GROUNDED FAULT OF PIPELINE (OPTIONAL FUNCTION)

The grounded fault of pipeline included: A. Insulation protection layer damage of insulated pipe; B. Grounded fault of non-armor low voltage cable; C. Sheath fault of high voltage cable (especially for UHV single core cable). For these types fault, it usually uses step voltage to pinpoint with A-frame.

6.1 SIGNAL TRANSMITTING

First, disconnect all the grounded connection of the pipeline, and keep it in reliable floating insulation. The transmitter works in direct connection mode, the black alligator clip of direct connection lead should connect with grounded stick, the red alligator clip should connect with the fault pipeline: **A.** For the protective layer damage of insulated pipe: the red alligator clip should connect with the metal part of the pipe. **B.** For the grounded fault of non-armor low voltage cable: the red alligator clip should connect with the fault phase. **C.** For the sheath fault of high voltage cable: the red alligator clip should connect with the sheath. As an example of non-armor low voltage cable, the connection is shown in the fig. 6.1

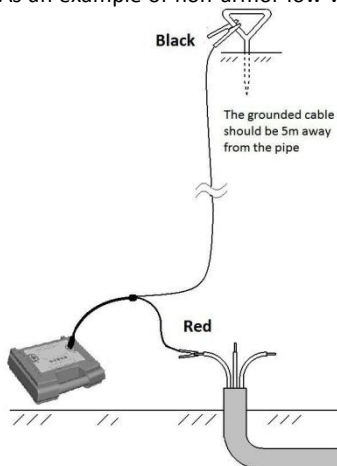

Fig.6.1 Connection for grounded fault pinpoint



RCI-600P Pipe Locating System



- The position selected of grounded stick: the stick should be drilled at a distance of 5 m outside the pipe, the black grounded wire and pipe should be perpendicular.
- The grounded wire can't be connected to the water pipe or other pipes, because it will interfere the pinpointing.
- It is better there is no other pipeline between the spike and the tested pipeline. Before drilling the stick, you should check with the passive detection method.
- When signal transmitted in substation, the stick can't be used to connect to the ground, so the ground grid can be used as grounded point. But if fault happens in region of ground grid, Instrument may not accurately reflect fault.
- Fault locating only use the 640Hz, and set the output frequency to highest.

6.2 ACCESSORIES CONNECTION

Assembling the A frame:

Screw the two probes into the hole on the frame bottom. Contact the receiver accessories connection line (with blue mark) with A frame port and receiver accessories input port. Noticed to lock all the connectors. Refer below Fig. 6.2

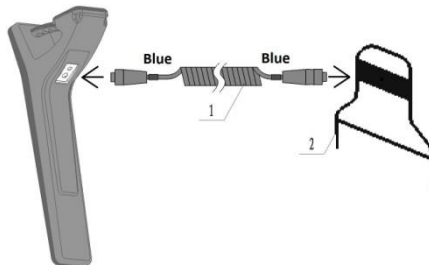

Fig.6.2 Connection for A frame



RCI-600P Pipe Locating System

6.3 INTERFACE INTRODUCTION

After power on, device will automatically distinguish the connected accessories and set as A frame receiving mode, interface as below Fig. 6.3

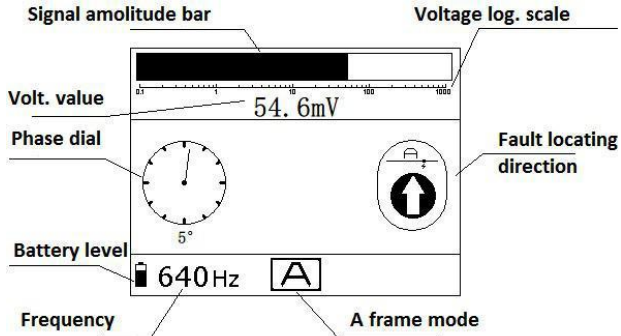

Fig.6.3 Interface for A frame fault location

6.4 CONFIRMATORY TESTS AT NEAR-END

Before detection, it is suggested first do the confirmatory test near the stick, and to determine whether this method can be used to detect the fault.

The signal is injected to pipeline from transmitter, and leak out to the ground at the fault point. The leakage current will gather to the spike, then return to the transmitter. If the receiver can get the strong enough signal near the spike, and it has right direction response, that is to say the injected signal is strong enough, it can content the requirement of detection; Near the spike the signal will be strongest, if there is no right response, that is to say maybe the fault impedance is too high, the current injected is too small, so the fault can't be detected.



Tests at near-end: The probe of A-frame should be drilled into the ground far away from the grounded stick at a distance of 1m. A-frame red end should point to the end of the

pipeline direction. Check the voltage and phase, if both value is stable, it means the receiving is normal.

Set reference: press receiver Set ref. Button  ,and screen top left corner will display



to check whether to do A frame setting reference. Press other buttons to exit

and press Set ref. Button  again to finish setting, now screen shows  . And

now the current phase return to zero, the phase dial points to the right upward side. The

angle on the bottom of dial begins to 0°, the fault locating direction is forward .

If the voltage value is very small, the phase is also not very stable, it means the injected signal is too small to receiver. Possible reasons: Error wiring, or fault resistance it too high to form valid testing current.

Circle Confirmatory Test: If receiving well , according to black near and red far principle, (black near end, red far end) , around the grounded stick for one circle , there will be stable response and the arrow always should point to forward.

Determine the response range: From the near-end of pipeline, start the confirmatory test gradually, the red end of A-frame should point to the pipe terminal. Along with the distance increasing, the signal is reducing gradually, phase will be unstable, and the locating direction may points to back sometimes. When the signal can also just be distinguished correctly, record the location, the distance between this position to earth stick will be the max. one-way responding range.

Considers pipeline's buried environmental factor (Such as extra high voltage cables installed in cable trench , you only can do confirmatory test outside the trench), the fault point response range is smaller than the grounded stick response range generally. So, we suggest that the 1/3 — 1/2 of the response range should be as the confirmatory test spacing. For example, the measured response range is 20m, the suggested confirmatory

test spacing will be 6—10m. When we take this value as spacing to detect, we can avoid missing the fault point, and also can accelerate the test speed.

If using the grounded grid of power substation as the ground of transmitter, the confirmatory test can't be done. The suggested confirmatory test spacing is 3—5m, it can meet most need. If the fault impedance is higher, the spacing should be reduced.

6.5 FAULT LOCATING CONFIRMATORY TESTS

From the near-end of pipeline, facing the terminal, red end of A-frame pointing to the terminal, we start the confirmatory test with the same spacing and gain every time. At beginning, because near the earth stick, the signal is strong and stable, the arrow points to forward. With the distance increasing, the voltage is reducing gradually. Going on forward to test, until find the stable point, that is to say we are closing the fault point. Observing the arrow: the arrow pointing to forward means fault point in front; the arrow pointing to backward means fault point in behind. According to the arrow direction, we gradually approximate to the fault point, and during this process to reduce test distance gradually. Finally, when the fault point is right located between the two probes of A-frame, the voltage intensity will

have a sudden drop, and a little movement will have acute changes. Moving the A-frame at a small spacing, you will find a point. It is the lowest intensity point with direction suddenly dropping. This is the fault point. The A frame fault location

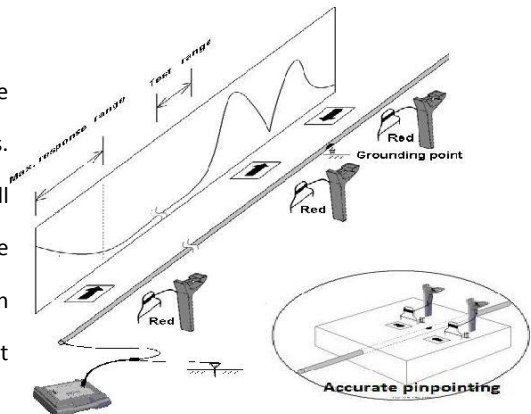

process refer Fig. 6.4



- When locating, the operator need to face to the pipe terminal and make the A frame red side in the front (points to the pipe terminal), and the receiver direction need to be same (face to the pipe terminal).
- If the cable is laying in cement cable trench, and is covered with cement cover, the best detection position is upon the ground, and not upon the cement cover.
- If the cable was below the surface hardening road (bitumen, cement or brick), you'd better do the detection in the grass/earth beside the road. If it is too far away from the cable, the detection result will be worse. Then we suggest to reduce the test spacing.
- If you directly in dry and surface hardening road detect, the effect is poorer. The wet surface will be better than it.
- This method can't be used to detect phase grounded fault of armor cable. Because the armor is very possible to multi- points grounding, and these points all will be measured as fault points and it's difficult to distinguish real fault position.

7. CABLE FAULT PINPOINT FOR LOW IMPEDANCE AND BREAK FAULT

This chapter is an auxiliary one, read it if needed.

When the cable fault impedance is lower, if use the HV impulse current method to locate the fault, the voice of the fault point discharging is weak, especially when the metallic grounded there will be no voice. Acoustic Measurement precision fixed-point failure,so we need to use the audio frequency induction method.

Audio frequency induction method is used in the low impedance fault that the resistance is no more than 10 Ohm. Using the Audio frequency induction method to locate the fault of two phase or three phase short circuit (or combined grounded), we can get a satisfying result, the general location error is 1-2 m.

For the break fault, we also can use Audio frequency induction method.

7.1 PHASE TO PHASE SHORT CIRCUIT FAULT PINPOINTING

7.1.1 Signal transmitting method

As shown in Fig. 7.1, first disconnect the connection between the both ends of cable metal sheath and ground. The connection between the null line of low voltage cable and ground also should be disconnected.

The transmitter is in the direct

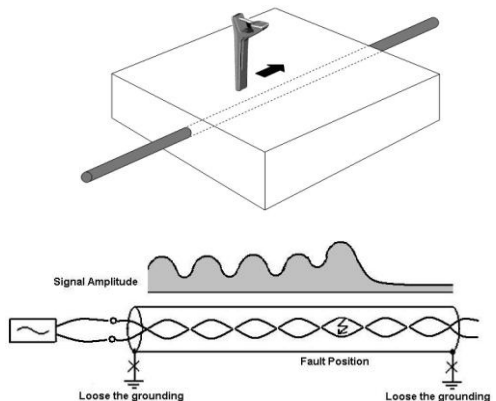



connection output mode, and should connect to two fault core wires. **The receiver must be moving parallel to the cable**, and use the peak method to detect.

7.1.2 Pinpointing method

As the cable twist wire along the cable path forward, before the fault point, when we move forward along the path, the signal amplitude will regularly change according to cable torque. When we is in the upward of the fault point, we will get the strongest signal amplitude. If we move forward on, the signal amplitude will reduce to a little and stable value. The receiver will show the similar history curve with the signal amplitude curve shown in above Fig. 7.1.

7.1.3 Attention

- For the fault impedance: should be close to 0 with the meg meter measured, no more than 10 Ohm. If over 10 Ohm, should be burned down to low impedance first. If the measurement is 0 with the mega-meter, that doesn' t mean the fault is low impedance fault, you must measure with the multi-meter.
- All the grounded connection of cable metal sheath should be disconnected, the connection between the null line of low voltage cable and ground also should be disconnected, it is to avoid the interference of other signal.
- Before location, we should find the path first, and marked, otherwise, it is easily to upset the signal rhythm for rising and falling.
- Please note the receiver should be parallel to the cable path, and use the peak method.
- As the connection is between the phases, the effective signal is little, so it is easier to detect using the high frequency signal than the low frequency signal.



But the remainder of the high frequency after the fault point is more. We can select the frequency according to the fault impedance. If the impedance is very low, we select the little high frequency (like 8 kHz), if the impedance is higher, we select the low frequency (like 1kHz).

- From the near end, check for changes in pitch, if on change, that is to say the fault point is in the near end.
- Before the fault point, the pitch will have some changes. Above the fault point, we can get the maximum value. After the fault point, the signal amplitude will reduce to a little and stable value.
- As we have marked the cable path, so we can go forward at normal speed by foot. Slow walking is not necessary. For the power cable, the pitch is generally among 1/3m to 1m.
- If the signal breaks or reduces to a little and stable value, that means the fault point is under the last peak of signal. But there also are other reasons: ① Increasing depth; ② There is unmarked branch, the fault point is in the branch, but the operator goes on walking along the main cable; ③ Connector. For all situation, the operator should have no hesitancy to go on walking forward, and remembered the last peak position in your head. It is easier to distinguish the connector, the signal is dropping for a little time, and then recovers immediately. If the depth of cable is increasing, you will keep on receiving the signal with pitch changing, so don't worry about it.
- This is the only method that can locate the short-circuit fault point for low voltage, more multi-connection and with a load of cable. As the pitch is too small, this method can not be used in telecom cable and control cable. But if we can touch the cable, the method also can be used.

7.2 PHASE TO ARMOR FAULT PINPOINTING

7.2.1 Signal transmitting method

For the low impedance grounded fault of phase to armor, we should use one variation connection of inter-phase. As shown in Figure 7.2, first we should disconnect the connection between the both ends of cable metal sheath and ground. The connection between the null line of low voltage cable and ground also should be disconnected, the output of the signal transmitter should connect between one good phase and the armor. At the other end of the cable, the fault phase and the good phase connected with the signal should be short-circuit. Receiver should parallelly move long the cable.

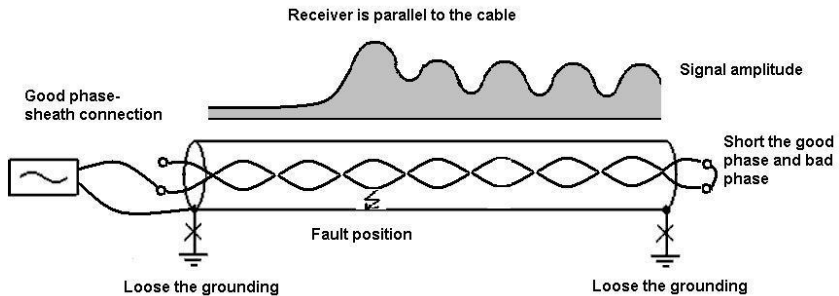

Fig.7.2 Phase to armor grounded fault pinpointing

7.2.2 Pinpointing method

This method is similar as the pinpointing method of Phase to phase, but need to notice: before the fault point, the signal amplitude is stable but small. After the fault points, the pitch has some change and the fault point above the first peak value.

7.3 BREAK FAULT PINPOINTING

7.3.1 Signal transmitting method

For the break fault, the transmitter direction connection output is between the faulty phase and ground, don't need to deal with the opposite end. The signal travels from the transmitter to the fault phase cable, it will stop at the break fault point. For the pure break fault, before the fault point, the current flows to the ground through the distributed capacitance between the fault phase and ground, then returns to the transmitter. For the most low voltage cable without armor, if it has the break fault, it generally also will have the grounded fault. The current is flowing to the ground through the fault point mainly, and then it will return to the transmitter. Refer below Fig. 7.3

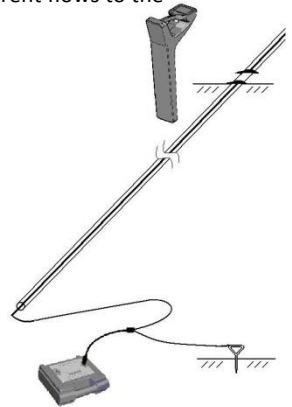

Fig.7.3 break fault testing wiring

7.3.2 Pinpointing method

The pinpoint of break fault is the same with ordinary pipeline tracking. Keep the receiver being perpendicular to the cable, using the peak method, starting from the transmitter near-end, gradually move to the remote and detect. Before the fault point, the signal is strong, after the fault point, the signal decreased rapidly. The point that the signal started decreasing is the fault point. There is no pitch change.

As shown in Fig.7.4

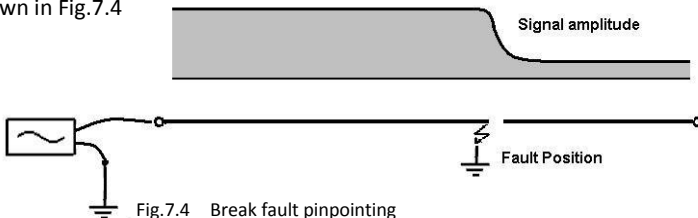

Fig.7.4 Break fault pinpointing



RCI-600P Pipe Locating System

- This method is particularly suitable for fault pinpoint of low voltage non-armor cable. For the armor cable, the current will couple to the armor through the distributed capacitor. So the signal will in all the length of cable, and can't distinguish where the fault happens.
- For the break merging grounded fault, we suggest using the lower frequency (like 1280 Hz). For the pure break fault, should use the higher frequency (like 10 kHz). The current value of transmitter can help you select the frequency. When it is low frequency and the current value is large, then should use the low frequency; if the current value is small, you should use the high frequency.
- For the pure break fault, with the increase in distance, the signal will continue to decrease. At the fault point, the signal disappears. For the break merging grounded fault, if the grounded impedance not a great, then the signal weakens the phenomenon not to be obvious.

7.4 BREAK FAULT PINPOINTING

7.4.1 Signal transmitting method

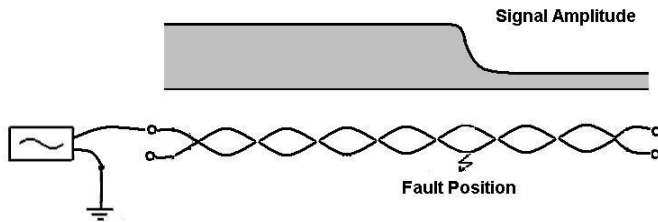

Fig.7.5 No armor cable phase to ground fault wiring

As above Fig. 7.5 shows, disconnect all the grounded in both ends of low voltage cable's null line and ground line, the transmitter is selected the direct connection mode and connected between the fault phase and ground. The signal flows from the transmitter to the fault phase, at the fault point it will flow to the ground and then return to the transmitter.

7.4.2 Pinpointing method

It is similar with the break fault. Keep the receiver being perpendicular to the cable, using the peak method, starting from the transmitter near end, gradually move to the remote and detect. Before the fault point, the signal is strong, after the fault point, the signal decreased rapidly. The point that the signal started decreasing is the fault point. There is no pitch change.



- Whether the induction method can be used to pinpoint the grounded fault, it mainly depends on the value of fault impedance.
The greater the fault resistance, signal changes before and after the fault more weak, that they can not distinguish.
- The lower the frequency, intensity changes before and after the point of fault more obvious. It proposes to adopt low-frequency detection (like 640Hz or 1280 Hz).
- For the fault of phase to ground, the step voltage method is the dominant method that was introduced in Chapter VIII, and this method as a supplementary. Before using the step voltage method to pinpoint, you should first detect the cable path. In the path tracking, observe whether the signal amplitude have obvious change. If have, this is a suspicious points, you should mainly pinpoint in this region using the step voltage method; if no, that is to say this method can't be used, you should use step voltage method.



8. DEVICE MAINTAIN AND WARRANTY

8.1 CHARGING

Device adopts built-in Lithium battery. According different output level the work time is also different. Common enough for 8 hours working every day.

During the using ,there will be a battery level indicating mark in the bottom left corner.

The black bar instead battery level, all black means full power, all blank and flash means low battery level. When appear mark , instead power use up and will auto power off in several seconds.

If need charging, insert the charger plug into the transmitter/receiver Charge port. Charger AC plug connects 220V/110V mains supply.

When charging, if charger indicator is red it means in charging, while green means completed. Keep charging for some time is helpful for charging more power.

Under the power off condition, receiver charging from low battery to full needs about 3-4 hours and receiver needs about 1.5-2 hours.

According different using and maintaining condition, the battery group common supports 300-500 charging-discharging cycles. According the increase of charging-discharging, the battery capacity will gradually step down, corresponding the device working time will step down.

Change battery when need. Standard battery is 18650 Lithium battery, capacity is above 3400mAH, suggested the Panasonic NCR18650B(3400mAH) or larger capacity models.

Transmitter needs 4 PCS batteries, receiver needs 2 PCS batteries.

Attention for the battery plus-n-minus when installation.



8.2 WARRANTY AND MAINTIAN

Device main unit and accessories are one year guarantee of free maintain, battery is one year free replacement. Beyond one year, only charge for basic component cost for maintaining.

For device breakdown by incorrect using (in the warranty) or device quality problems over warranty, we are responsible for maintaining and only charge basic component cost.

When auto power-off, unable to power on or immediately shut after power on, it's possible because low battery. Charging first and again.

If other problems, don't to maintain by yourself, contact with us first.

(manual version:V5.0)